

SECTION **RAX**  
REAR AXLE

A  
B  
C

RAX

CONTENTS

E

<b>SERVICE INFORMATION</b> .....	2	<b>WHEEL HUB</b> .....	5	F
<b>PRECAUTIONS</b> .....	2	On-Vehicle Inspection .....	5	
Caution .....	2	Removal and Installation .....	5	G
<b>PREPARATION</b> .....	3	<b>REAR DRIVE SHAFT</b> .....	9	
Special Service Tool .....	3	Removal and Installation .....	9	H
Commercial Service Tool .....	3	Disassembly and Assembly .....	11	
<b>NOISE, VIBRATION AND HARSHNESS</b>		<b>SERVICE DATA AND SPECIFICATIONS</b>		
<b>(NVH) TROUBLESHOOTING</b> .....	4	<b>(SDS)</b> .....	16	I
NVH Troubleshooting Chart .....	4	Wheel Bearing .....	16	
		Drive Shaft .....	16	J

J

K

L

M

N

O

P

# PRECAUTIONS

< SERVICE INFORMATION >

---

## SERVICE INFORMATION

### PRECAUTIONS

#### Caution

INFOID:000000005351827

Observe the following precautions when disassembling and assembling drive shaft.

- Joint sub-assembly does not disassemble because it is non-overhaul parts.
- Perform work in a location which is as dust-free as possible.
- Before disassembling and assembling, clean the outside of parts.
- Prevention of the entry of foreign objects must be taken into account during disassembly of the service location.
- Disassembled parts must be carefully reassembled in the correct order. If work is interrupted, a clean cover must be placed over parts.
- Paper shop cloths must be used. Fabric shop cloths must not be used because of the danger of lint adhering to parts.
- Disassembled parts (except for rubber parts) should be cleaned with kerosene which shall be removed by blowing with air or wiping with paper shop cloths.

# PREPARATION

< SERVICE INFORMATION >

## PREPARATION

### Special Service Tool

INFOID:000000005351828

The actual shapes of Kent-Moore tools may differ from those of special service tools illustrated here.

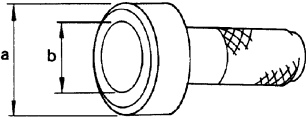
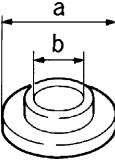
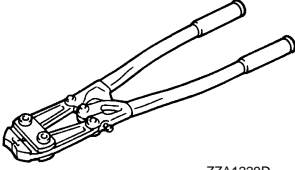
Tool number (Kent-Moore No.) Tool name	Description
KV38100500 ( — ) Drift a: 80 mm (3.15 in) dia. b: 60 mm (2.36 in) dia.	 <p style="text-align: center;">ZZA0701D</p> Installing drive shaft plug
KV38102200 ( — ) Drift a: 90 mm (3.54 in) dia. b: 31 mm (1.22 in) dia.	 <p style="text-align: center;">ZZA0920D</p> Installing drive shaft plug
KV40107300 ( — ) Boot band crimping tool	 <p style="text-align: center;">ZZA1229D</p> Installing boot band

### Commercial Service Tool

INFOID:000000005351829

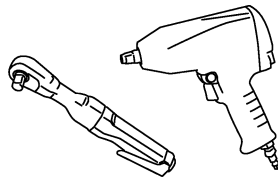
Tool name	Description
Power tool	 <p style="text-align: center;">PBIC0190E</p> <ul style="list-style-type: none"> <li>• Removing wheel nuts</li> <li>• Removing brake caliper assembly</li> <li>• Removing suspension links</li> <li>• Removing drive shaft</li> </ul>

# NOISE, VIBRATION AND HARSHNESS (NVH) TROUBLESHOOTING

< SERVICE INFORMATION >

## NOISE, VIBRATION AND HARSHNESS (NVH) TROUBLESHOOTING

### NVH Troubleshooting Chart

INFOID:000000005351830

Use chart below to find the cause of the symptom. If necessary, repair or replace these parts.

Reference page			—	RAX-11	—	RAX-9	—	NVH in PR section.	NVH in RFD section.	NVH in RAX and RSU sections.	Refer to REAR AXLE in this chart.	NVH in WT section.	NVH in WT section.	Refer to DRIVE SHAFT in this chart.	NVH in BR section.	NVH in PS section.	
Possible cause and SUSPECTED PARTS			Excessive joint angle	Joint sliding resistance	Imbalance	Improper installation, looseness	Parts interference	PROPELLER SHAFT	DIFFERENTIAL	REAR AXLE AND REAR SUSPENSION	REAR AXLE	TIRES	ROAD WHEEL	DRIVE SHAFT	BRAKES	STEERING	
Symptom	DRIVE SHAFT	Noise	×	×				×	×	×	×	×	×		×	×	
		Shake	×		×			×		×	×	×	×		×	×	
	REAR AXLE	Noise				×	×	×	×	×		×	×	×	×	×	×
		Shake				×	×	×		×		×	×	×	×	×	×
		Vibration				×	×	×		×		×		×			×
		Shimmy				×	×			×		×	×			×	×
		Judder				×				×		×	×			×	×
		Poor quality ride or handling				×	×			×		×	×				

×: Applicable

# WHEEL HUB

< SERVICE INFORMATION >

## WHEEL HUB

### On-Vehicle Inspection

INFOID:000000005351831

Make sure the mounting conditions (looseness, back lash) of each component and component conditions (wear, damage) are normal.

### WHEEL BEARING INSPECTION

- Move wheel hub and bearing assembly in the axial direction by hand. Make sure there is no looseness of wheel bearing.

**Axial end play : 0.05 mm (0.002 in) or less**

- Rotate wheel hub, and make sure that is no unusual noise or other irregular conditions. If there is any of irregular conditions, replace wheel hub and bearing assembly.

### Removal and Installation

INFOID:000000005351832

### COMPONENT

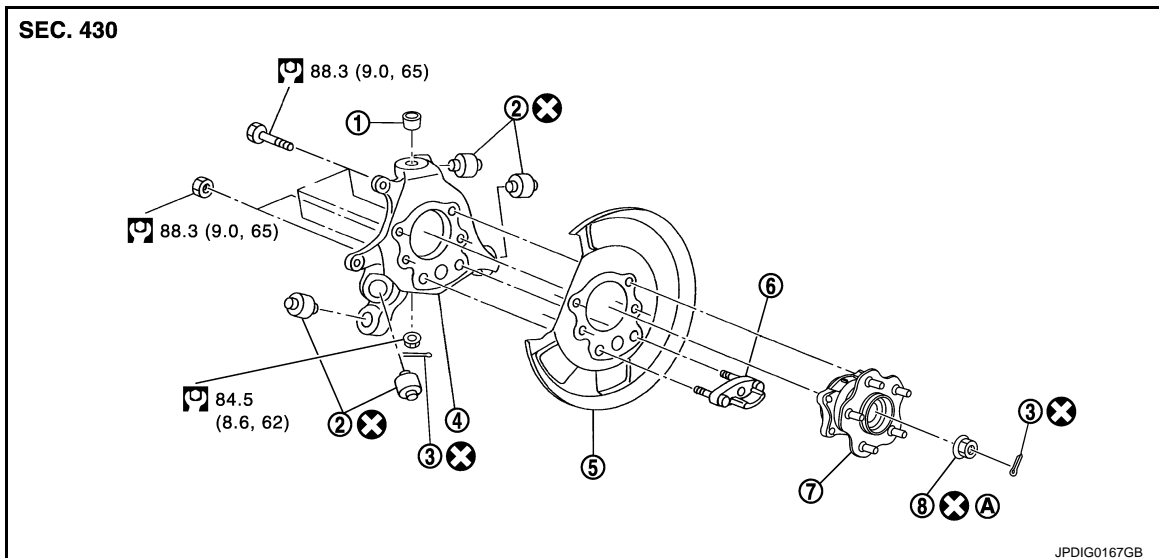

- |                                   |                       |                 |
|-----------------------------------|-----------------------|-----------------|
| 1. Ball seat                      | 2. Bushing            | 3. Cotter pin   |
| 4. Axle housing                   | 5. Back plate         | 6. Anchor block |
| 7. Wheel hub and bearing assembly | 8. Wheel hub lock nut |                 |

A. Tightening must be done following the installation procedure. Refer to "INSTALLATION".

Refer to [GI-9, "Component"](#), for the symbols in the figure.

### REMOVAL

#### Wheel Hub and Bearing Assembly

1. Remove tires from vehicle with a power tool.
2. Remove rear brake caliper with a power tool. Hang it in a place where it will not interfere with work. Refer to [BR-28, "Removal and Installation of Brake Caliper Assembly"](#).

#### **CAUTION:**

**Do not depress brake pedal while brake caliper is removed.**

# WHEEL HUB

## < SERVICE INFORMATION >

- Put matching mark (A) on disc rotor and the wheel hub and bearing assembly then removing disc rotor.
- Remove cotter pin, then loosen wheel hub lock nut with a power tool.

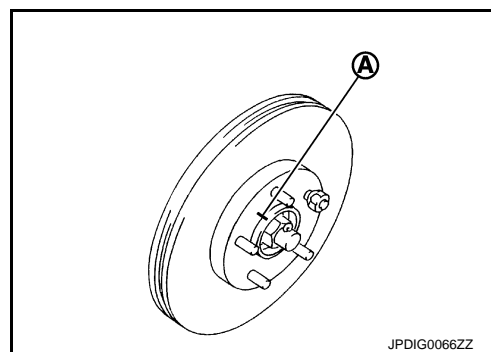

- Separate the wheel hub and bearing assembly from drive shaft by lightly tapping the end with a hammer (suitable tool) and wood block, and then remove wheel hub lock nut.

### CAUTION:

- Do not place drive shaft joint at an extreme angle. Also be careful not to overextend slide joint.
- Do not allow drive shaft to hang down without support for housing (or joint sub-assembly), shaft and other parts.

### NOTE:

Use a puller (suitable tool), if the wheel hub and bearing assembly and drive shaft cannot be separated even after performing the above procedure.

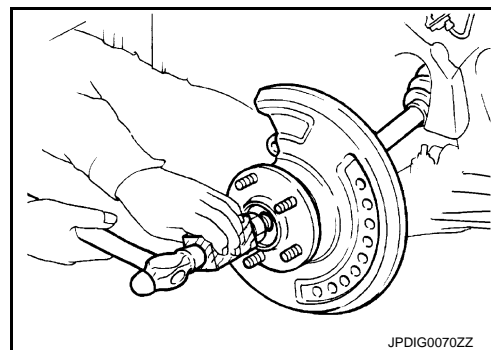

- Remove the wheel hub and bearing assembly mounting bolts.
- Remove the wheel hub and bearing assembly.

## Axle Housing

- Refer to the procedure from 1 to 5 in "Wheel Hub and Bearing Assembly". "REMOVAL".
- Remove parking brake shoe and parking brake cable from back plate. Refer to [PB-6](#), Refer to [PB-4](#).
- Remove coil spring. Refer to [RSU-15](#).
- Remove mounting bolt and nut in axle side of shock absorber with a power tool.
- Remove axle side nuts and bolts on radius rod and front lower link with a power tool. Refer to [RSU-13](#), [RSU-14](#).
- Remove cotter pin, then loosen suspension arm mounting nut of axle housing.
- Remove suspension arm from axle housing so as not to damage ball joint boot using ball joint remover (suitable tool), and then remove axle housing from the vehicle.

### CAUTION:

- Temporarily tighten nuts to prevent damage to threads and to prevent ball joint remover (suitable tool) from coming off.
- Do not place drive shaft joint at an extreme angle. Also be careful not to overextend slide joint.
- Do not allow drive shaft to hang down without support for counterpart such as joint sub-assembly, and other parts.

- Remove the wheel hub and bearing assembly from axle housing.
- Remove anchor block mounting nuts, and then remove anchor block and back plate from axle housing.

## INSPECTION AFTER REMOVAL

### Wheel Hub and Bearing Assembly

Check the wheel hub and bearing assembly for wear, cracks, and damage. Replace if there are.

### Axle Housing

Check axle housing for wear, cracks, and damage. Replace if there are.

### Ball Joint Inspection

Check for boot breakage, axial looseness, and torque of suspension arm ball joint. Refer to [RSU-11](#).

## INSTALLATION

### Wheel Hub and Bearing Assembly

Note the following, and install in the reverse order of removal.

# WHEEL HUB

## < SERVICE INFORMATION >

- Clean the matching surface of wheel hub lock nut and wheel hub and bearing assembly.

**CAUTION:**

**Never apply lubricating oil to these matching surface.**

- Clean the matching surface of drive shaft and wheel hub and bearing assembly. And then apply paste [service parts (440037S000)] to surface (A) of joint sub-assembly of drive shaft.

**CAUTION:**

**Apply paste to cover entire flat surface of joint sub-assembly of drive shaft.**

**Amount paste : 1.0 – 3.0 g (0.04 – 0.10 oz)**

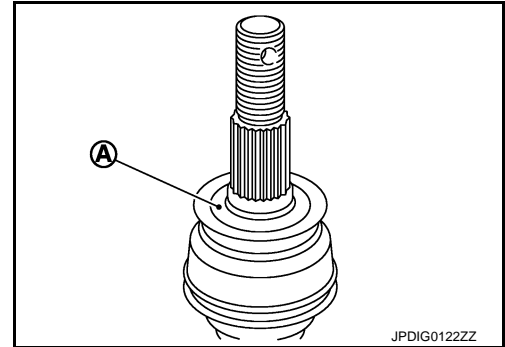

- Use the following torque range for tightening the wheel hub lock nut.

 : 180 N·m (18.4 kg-m, 133 ft-lb) – 185 N·m (18.8 kg-m, 136 ft-lb)

**CAUTION:**

- **Since the drive shaft is assembled by press-fitting, use the tightening torque range for the wheel hub lock nut.**
- **Be sure to use torque wrench to tighten the wheel hub lock nut. Never use a power tool.**

**NOTE:**

Wheel hub lock nut tightening torque does not over torque for avoiding axle noise, and does not less than torque for avoiding looseness.

- Never use a power tool to tighten the wheel hub lock nut.
- Perform the final tightening of each of parts under unladen conditions, which were removed when removing wheel hub and bearing assembly and axle housing.
- Never reuse cotter pin, wheel hub lock nut and bushing.
- Assemble disc rotor and the wheel hub and bearing assembly by aligning each matching mark (A) as shown in the figure when installing disc rotor.

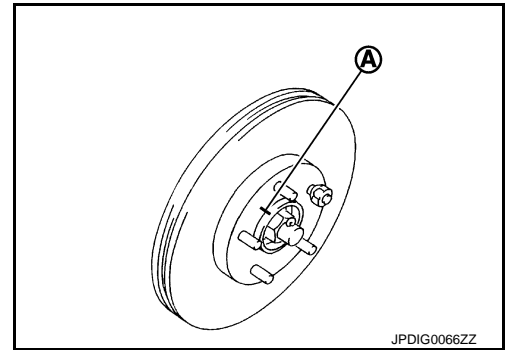

### Axle Housing

Note the following, and install in the reverse order of removal.

- Clean the matching surface of wheel hub lock nut and wheel hub and bearing assembly.

**CAUTION:**

**Never apply lubricating oil to these matching surface.**

- Clean the matching surface of drive shaft and wheel hub and bearing assembly. And then apply paste [service parts (440037S000)] to surface (A) of joint sub-assembly of drive shaft.

**CAUTION:**

**Apply paste to cover entire flat surface of joint sub-assembly of drive shaft.**

**Amount paste : 1.0 – 3.0 g (0.04 – 0.10 oz)**

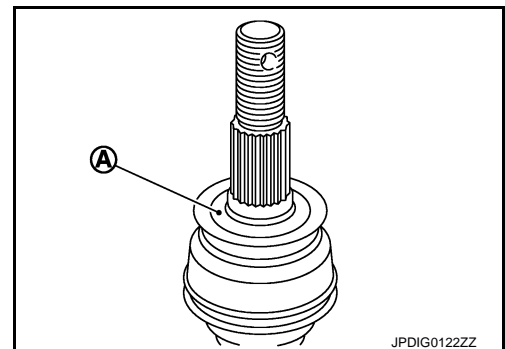

- Use the following torque range for tightening the wheel hub lock nut.

A  
B  
C  
RAX  
E  
F  
G  
H  
I  
J  
K  
L  
M  
N  
O  
P

## WHEEL HUB

< SERVICE INFORMATION >

---

 : 180 N·m (18.4 kg-m, 133 ft-lb) – 185 N·m (18.8 kg-m, 136 ft-lb)

### CAUTION:

- Since the drive shaft is assembled by press-fitting, use the tightening torque range for the wheel hub lock nut.
- Be sure to use torque wrench to tighten the wheel hub lock nut. Never use a power tool.

### NOTE:

Wheel hub lock nut tightening torque does not over torque for avoiding axle noise, and does not less than torque for avoiding looseness.

- Never use a power tool to tighten the wheel hub lock nut.
- Perform the final tightening of each of parts under unladen conditions, which were removed when removing wheel hub and bearing assembly and axle housing.
- Never reuse cotter pin, wheel hub lock nut and bushing.
- Assemble disc rotor and the wheel hub and bearing assembly by aligning each matching mark (A) as shown in the figure when installing disc rotor.
- Perform final tightening of nuts and bolts on each link mounting part (rubber bushing) under unladen conditions with tires on level ground. Check wheel alignment. Refer to [RSU-5, "Wheel Alignment Inspection"](#).
- Adjust neutral position of steering angle sensor after checking wheel alignment. Refer to [BRC-8](#).

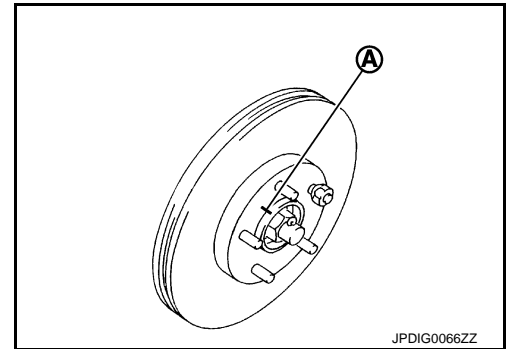



# REAR DRIVE SHAFT

< SERVICE INFORMATION >

## REAR DRIVE SHAFT

### Removal and Installation

INFOID:000000005351833

#### COMPONENT

##### VQ35HR models

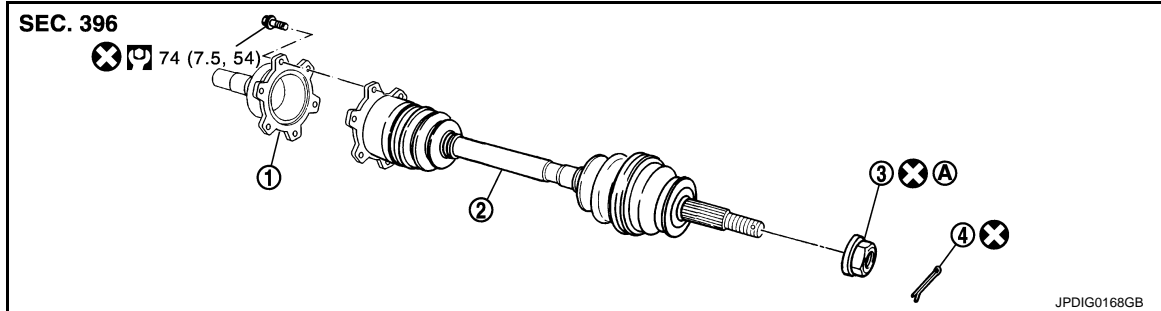

1. Side flange
  2. Drive shaft
  3. Wheel hub lock nut
  4. Cotter pin
- A. Tightening must be done following the installation procedure. Refer to "INSTALLATION".

Refer to [GI-9, "Component"](#), for the symbols in the figure.

##### VK45DE models

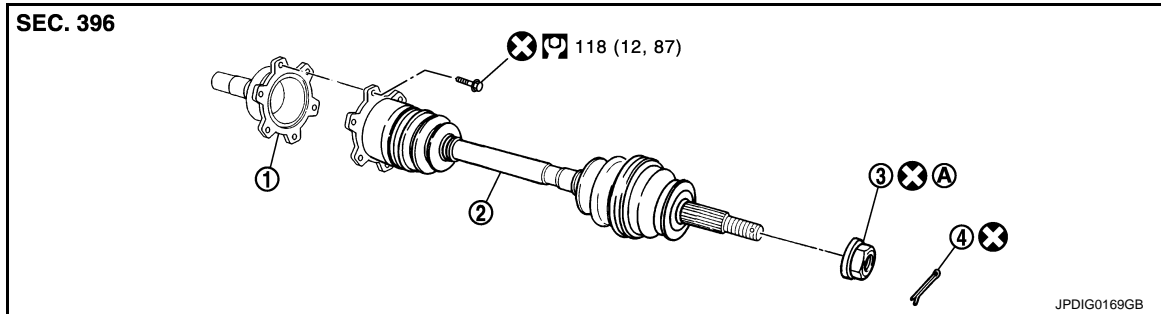

1. Side flange
  2. Drive shaft
  3. Wheel hub lock nut
  4. Cotter pin
- A. Tightening must be done following the installation procedure. Refer to "INSTALLATION".

Refer to [GI-9, "Component"](#), for the symbols in the figure.

#### REMOVAL

1. Remove tires with power tool.
2. Remove cotter pin, then loosen wheel hub lock nut with power tool.
3. Remove stabilizer connecting rod mounting bracket fixing bolt and free stabilizer connecting rod. Refer to [RSU-7, "Component"](#).

# REAR DRIVE SHAFT

## < SERVICE INFORMATION >

4. Separate the wheel hub and bearing assembly from drive shaft by lightly tapping the end with a suitable tool hammer and wood block, and then remove wheel hub lock nut.

### CAUTION:

- Do not place drive shaft joint at an extreme angle. Also be careful not to overextend slide joint.
- Do not allow drive shaft to hang down without support for counterpart such as joint sub-assembly, and other parts.

### NOTE:

Using a puller (suitable tool) if the wheel hub and bearing assembly and drive shaft cannot be separated even after performing the above procedure.

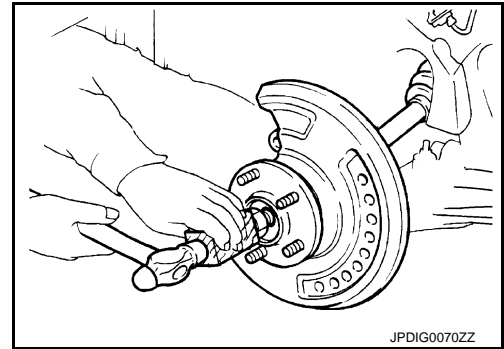

5. Remove mounting bolts between side flange and drive shaft with a power tool.

## INSPECTION AFTER REMOVAL

- Move joint up/down, left/right, and in the axial direction. Check for any rough movement or significant looseness.
- Check boot for cracks or other damage, and also for grease leakage.
- If a malfunction is found, disassemble drive shaft, and then replace with new one.

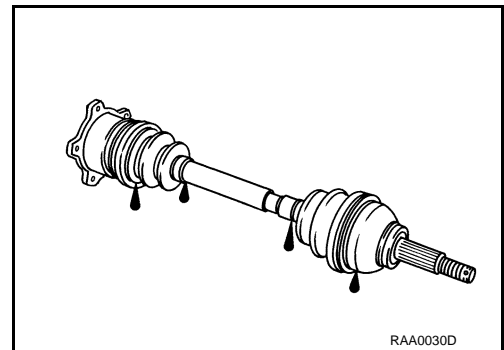

## INSTALLATION

Note the following, and install in the reverse order of removal.

- Clean the matching surface of wheel hub lock nut and wheel hub and bearing assembly.

### CAUTION:

**Never apply lubricating oil to these matching surface.**

- Clean the matching surface of drive shaft and wheel hub and bearing assembly. And then apply paste [service parts (440037S000)] to surface (A) of joint sub-assembly of drive shaft.

### CAUTION:

**Apply paste to cover entire flat surface of joint sub-assembly of drive shaft.**

**Amount paste : 1.0 – 3.0 g (0.04 – 0.10 oz)**

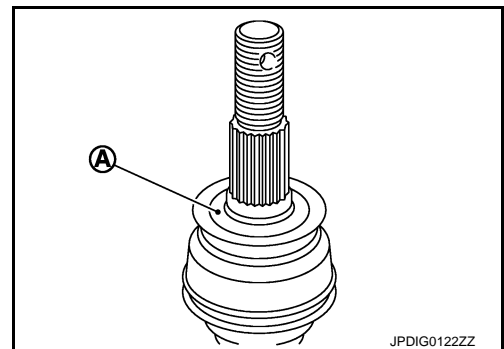

- Use the following torque range for tightening the wheel hub lock nut.

 : 180 N·m (18.4 kg·m, 133 ft·lb) – 185 N·m (18.8 kg·m, 136 ft·lb)

### CAUTION:

- Since the drive shaft is assembled by press-fitting, use the tightening torque range for the wheel hub lock nut.
- Be sure to use torque wrench to tighten the wheel hub lock nut. Never use a power tool.

### NOTE:

Wheel hub lock nut tightening torque does not over torque for avoiding axle noise, and does not less than torque for avoiding looseness.

- Never use a power tool to tighten the wheel hub lock nut.
- Perform the final tightening of each of parts under unladen conditions, which were removed when removing wheel hub and bearing assembly and axle housing.
- Never reuse cotter pin and wheel hub lock nut.

# REAR DRIVE SHAFT

< SERVICE INFORMATION >

## Disassembly and Assembly

INFOID:000000005351834

### COMPONENT

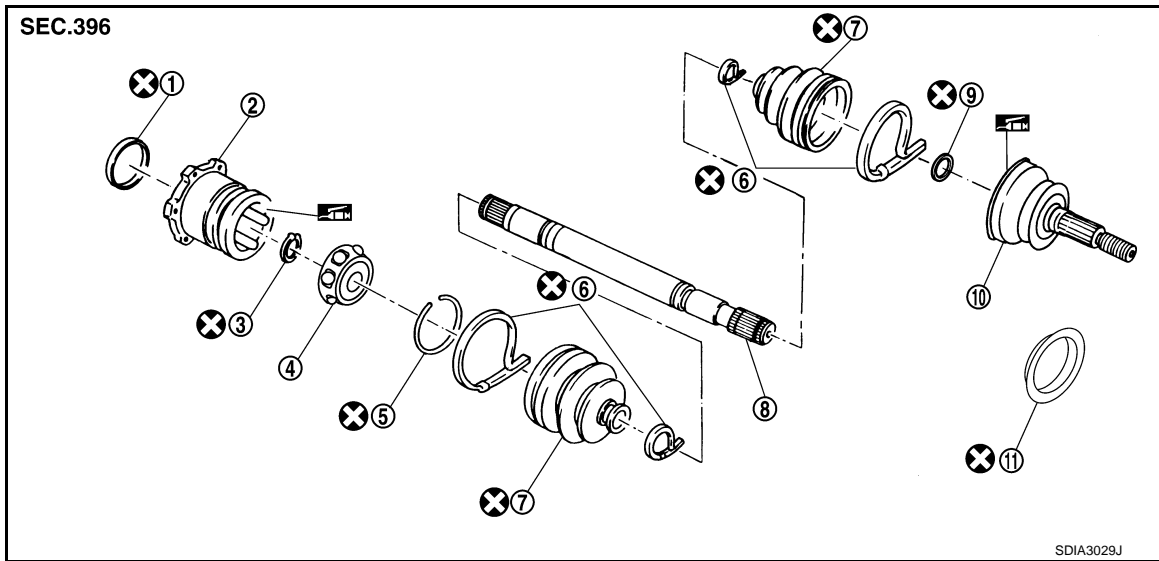

- |  |                 |                  |
|--|-----------------|------------------|
| 1. Plug  | 2. Housing      | 3. Snap ring     |
| 4. Ball cage, steel ball and Inner race assembly | 5. Stopper ring | 6. Boot band     |
| 7. Boot  | 8. Shaft        | 9. Circular clip |
| 10. Joint sub-assembly                           | 11. Dust shield |                  |

Refer to [GI-9, "Component"](#) and the followings for symbols in the figure.

 NISSAN genuine grease or equivalent

### DISASSEMBLY

#### Final Drive Side

- Place shaft in a vise.  
**CAUTION:**  
**When retaining shaft in a vise, always use copper or aluminum plates between vise and shaft.**
- Remove boot bands, and then remove boot from housing.
- If plug needs to be removed, move boot to wheel side, and take it out with a plastic hammer.
- Put matching marks on housing and shaft.  
**CAUTION:**  
**Use paint or similar substance for matching marks. Do not scratch the surface.**
- Remove stopper ring with a flat-bladed screwdriver, and pull out housing.

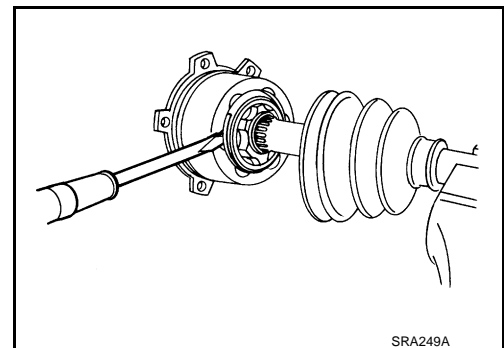

- Put matching marks on ball cage, steel ball and Inner race assembly and shaft.  
**CAUTION:**  
**Use paint or similar substance for matching marks. Do not scratch the surface.**

A  
B  
C  
RAX  
E  
F  
G  
H  
I  
J  
K  
L  
M  
N  
O  
P

# REAR DRIVE SHAFT

## < SERVICE INFORMATION >

7. Remove snap ring, then remove ball cage, steel ball and Inner race assembly from shaft.
8. Remove boot from shaft.
9. Remove old grease on housing with paper towels.

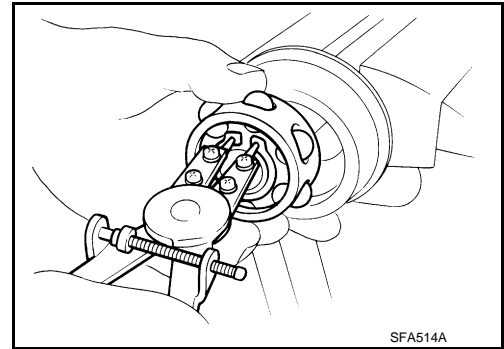

### Wheel Side

1. Remove dust shield from drive shaft.
2. Place shaft in a vise.

#### **CAUTION:**

**When retaining shaft in a vise, always use copper or aluminum plates between vise and shaft.**

3. Remove boot bands. Then remove boot from joint sub-assembly.
4. Screw the drive shaft puller (A) 30 mm (1.18 in) or more into the thread of joint sub-assembly, and pull joint sub-assembly with a sliding hammer (B) from shaft.

#### **CAUTION:**

- If joint sub-assembly cannot be removed after five or more unsuccessful attempts, replace shaft and joint sub-assembly as a set.
- Align sliding hammer and drive shaft and remove them by pulling directory.

5. Remove boot from shaft.
6. Remove circular clip from shaft.
7. While rotating ball cage, remove old grease on joint sub-assembly with paper towels.

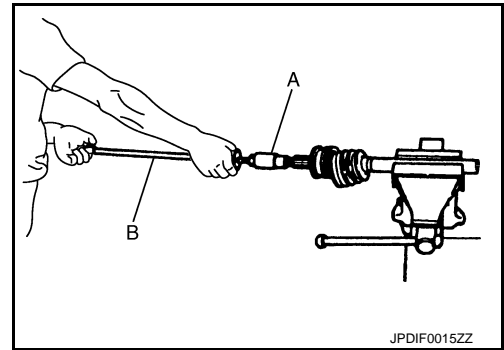

## INSPECTION AFTER DISASSEMBLY

### Shaft

Replace shaft if there is any runout, cracking, or other damage.

### Joint Sub-Assembly (Wheel Side)

- Check joint sub-assembly for rough rotation and excessive axial looseness.
  - Check the inside of the joint sub-assembly for entry of foreign material.
  - Check joint sub-assembly for compression scars, cracks, and fractures inside of joint sub-assembly.
- Replace joint sub-assembly if there are any non-standard conditions of components

#### **CAUTION:**

**If there are any irregular conditions of joint sub-assembly components, replace the entire joint sub-assembly.**

### Final Drive Side

- Make sure there are compression scars, cracks, fractures or unusual wear of ball rolling surface.
- Make sure there is no damage to shaft screws.
- Make sure there is no deformation of boot installation parts.

### Ball Cage

Make sure there are compression scars, cracks, fractures of sliding surface.

### Steel Ball

Make sure there are compression scars, cracks, fractures or unusual wear.

### Inner Race

- Check ball sliding surface for compression scars, cracks or fractures.
- Make sure there is no damage to serrated part.

#### **CAUTION:**

# REAR DRIVE SHAFT

## < SERVICE INFORMATION >

If there are any irregular conditions in the component, replace with a new set of housing and the ball cage, steel ball and inner race assembly.

### ASSEMBLY

Final Drive Side

1. If plug (1) has been removed, use a drift to press in a new one.

← : Press

A : Drift [SST: KV38100500 ( — )]

B : Drift [SST: KV38102200 ( — )]

**CAUTION:**  
Do not reuse plug.

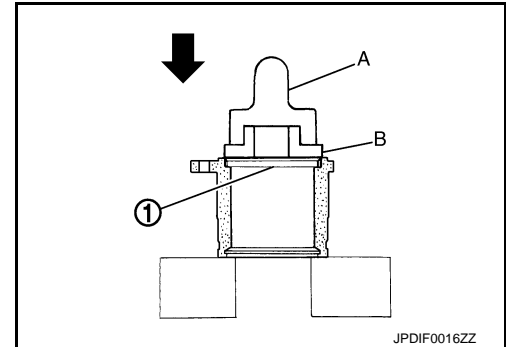

2. Wrap serrated part of shaft with tape (A). Install boot band and boot to shaft. Be careful not to damage boot.

**CAUTION:**  
Do not reuse boot band and boot.

3. Remove protective tape wrapped around serrated part of shaft.

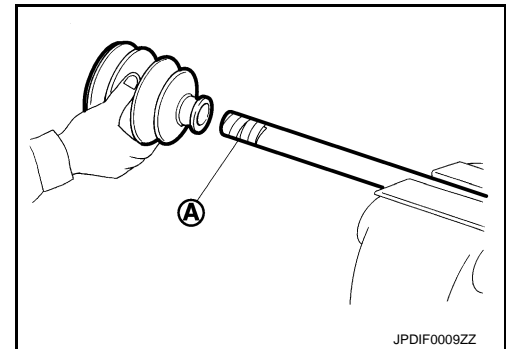

4. Install ball cage, steel ball and inner race assembly (1) to shaft (2), and secure them tightly with a snap ring (3).

**CAUTION:**  
Do not reuse snap ring.

**NOTE:**

Align matching marks painted when ball cage, steel ball and inner race assembly were removed.

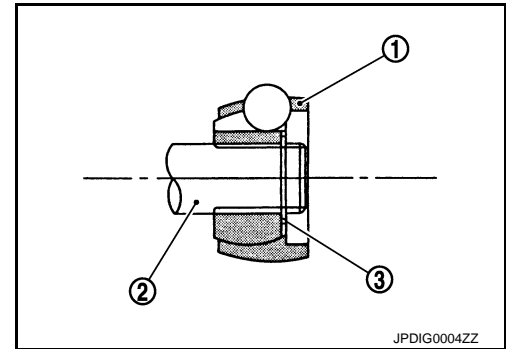

5. Apply the specified amount of grease (NISSAN genuine grease or equivalent) onto housing (\* point) and install it to shaft.

**NOTE:**

Align matching marks painted when housing were removed.

**Grease amount** : Refer to [RAX-16, "Drive Shaft"](#).

6. Install stopper ring to housing.
7. After installed, pull shaft to check engagement between joint sub-assembly and stopper ring.

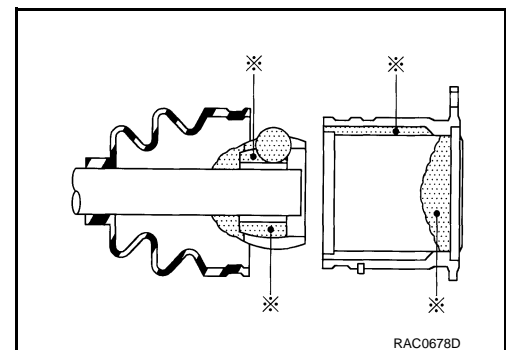

A  
B  
C  
RAX  
E  
F  
G  
H  
I  
J  
K  
L  
M  
N  
O  
P

## REAR DRIVE SHAFT

### < SERVICE INFORMATION >

8. Install boot securely into grooves (indicated by \*marks) shown in the figure.

**CAUTION:**

If there is grease on boot mounting surfaces (indicated by \* marks) of shaft and housing, boot may come off. Remove all grease from the surfaces.

9. Make sure boot installation length "L" is the length indicated below. Insert a flat-bladed screwdriver or similar tool into inside of boot from the large diameter side of boot. Bleed air from boot to prevent boot deformation.

Boot installation Length "L" : Refer to [RAX-16, "Drive Shaft"](#).

**CAUTION:**

- Boot may break if boot installation length is less than standard value.
- Take care not to touch the tip of screwdriver to inside of boot.

10. Secure large and small ends of boot with new boot bands as shown in the figure.

**CAUTION:**

Do not reuse boot band.

11. After installing housing and shaft, rotate boot to check whether or not the actual position is correct. If boot position is not correct, secure boot with new boot band again.

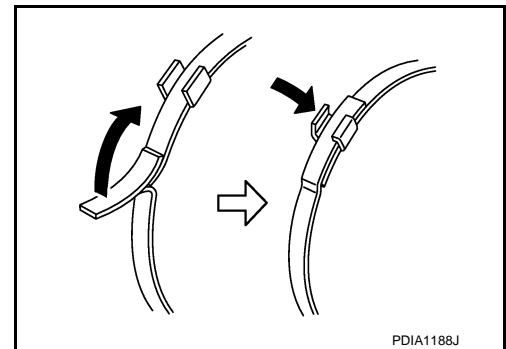
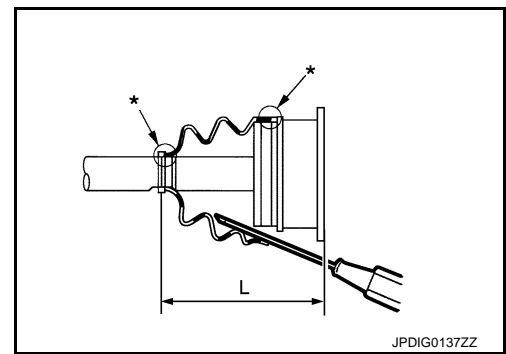

### Wheel Side

1. Apply the specified amount of grease (NISSAN genuine grease or equivalent) into joint sub-assembly (1) serration hole until grease begins to ooze from ball groove and serration hole. After applying grease, use a shop cloth to wipe off old grease that has oozed out.

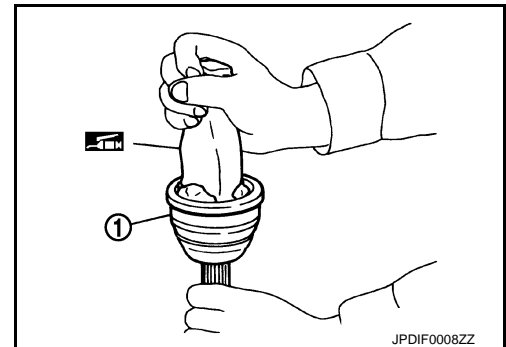

2. Wrap serrated part of shaft with tape (A). Install boot band and boot to shaft. Be careful not to damage boot.

**CAUTION:**

Do not reuse boot band and boot.

3. Remove protective tape wrapped around serrated part of shaft.

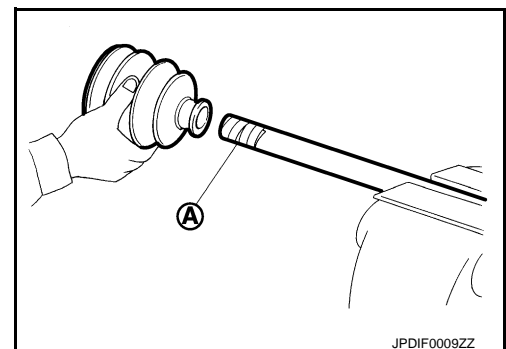

# REAR DRIVE SHAFT

## < SERVICE INFORMATION >

4. Attach circular clip to shaft. At this time, circular clip must fit securely into shaft groove. Attach nut to joint sub-assembly. Use a wooden hammer to press-fit.

**CAUTION:**

**Do not reuse circular clip.**

5. Apply the specified amount of grease (NISSAN genuine grease or equivalent) into housing from large end of boot.

**Grease amount** : Refer to [RAX-16, "Drive Shaft"](#).

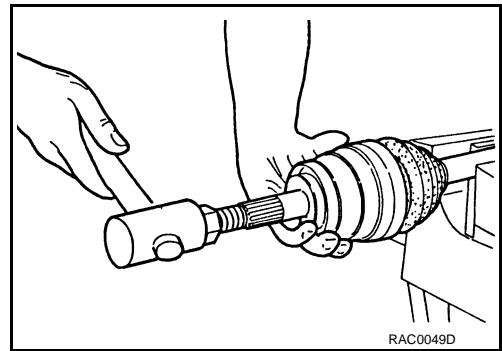

6. Install boot securely into grooves (indicated by \*marks) shown in the figure.

**CAUTION:**

**If there is grease on boot mounting surfaces (indicated by \* marks) of shaft and housing, boot may come off. Remove all grease from the surfaces.**

7. Make sure boot installation length "L" is the length indicated below. Insert a flat-bladed screwdriver or similar tool into inside of boot from the large diameter side of the boot. Bleed air from boot to prevent boot deformation.

**Boot installation Length "L"** : Refer to [RAX-16, "Drive Shaft"](#).

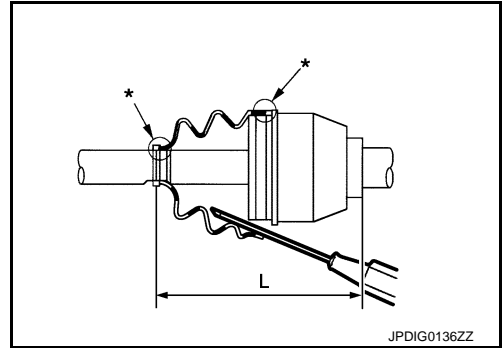

**CAUTION:**

- **Boot may brake if boot installation length is less than standard value.**
- **Be careful that screwdriver tip does not contact inside surface of boot.**

8. Secure the large and small ends of the boot with new boot bands using the boot band crimping tool [SST: KV40107300 ( - )] as shown in the figure.

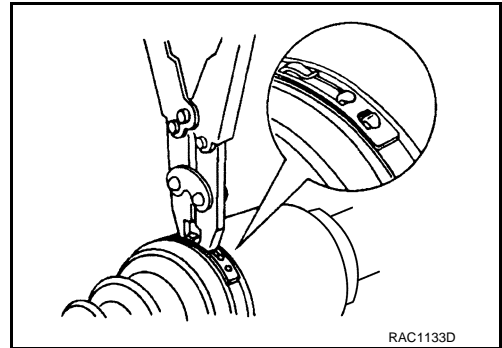

**NOTE:**

Secure boot band so that dimension "M" meets the specification as shown.

**Dimension "M"** : 2.0 – 3.0 mm (0.079 – 0.118 in)

9. Secure joint sub-assembly and shaft, and then make sure that they are in the correct position when rotating boot. Install them with new boot band when boot installation positions become incorrect.

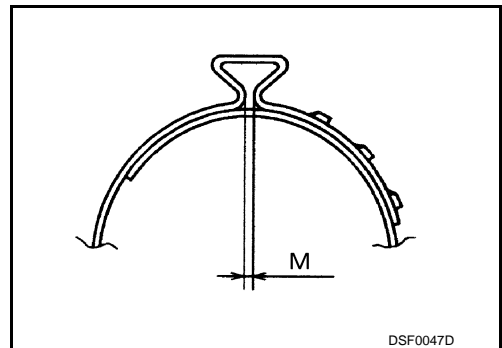

A  
B  
C  
RAX  
E  
F  
G  
H  
I  
J  
K  
L  
M  
N  
O  
P

# SERVICE DATA AND SPECIFICATIONS (SDS)

< SERVICE INFORMATION >

## SERVICE DATA AND SPECIFICATIONS (SDS)

### Wheel Bearing

INFOID:000000005351835

Item	Standard
Axial end play	0.05 mm (0.002 in) or less

### Drive Shaft

INFOID:000000005351836

#### VK45DE model

Since drive shafts vary with vehicle, carefully identify outside diameter (A) of joint sub-assembly and (B) of housing.

Item	Standard	
	Wheel side	Final drive side
Joint side		
Grease quantity	110 – 130 g (3.88 – 4.58 oz)	140 – 160 g (4.94 – 5.64 oz)
Boot installed length	136.1 mm (5.36 in)	145.0 mm (5.71 in)

#### VQ35HR model

Since drive shafts vary with vehicle, carefully identify outside diameter (A) of joint sub-assembly and (B) of housing.

Item	Standard	
	Wheel side	Final drive side
Joint side		
Grease quantity	110 – 130 g (3.88 – 4.58 oz)	105 – 125 g (3.71 – 4.40 oz)
Boot installed length	133.5 mm (5.26 in)	130.2 mm (5.13 in)